

# Instruction Manual

# GARUDAN®

GARUDAN GPS-0402 Series

GARUDAN GPS-0504 Series

GARUDAN GPS-0603 Series



ANITA B s.r.o.

Hliníky 2068

680 01 Boskovice

Czech Republic

tel: +420 516 454 774, +420 516 453 496

fax: +420 516 452 751

e-mail: [info@anita.cz](mailto:info@anita.cz)

# CONTENTS



<b>1. Machine Safety Regulations</b>	<b>8</b>
1-1) Machine Transportation	8
1-2) Machine Installation	8
1-3) Machine Repair	8
1-4) Machine Operation	9
1-5) Devices for Safety	9
1-6) Caution Mark Position	10
1-7) Contents of Marks	10
<b>2. Electronically Controlled Bartacking SM Specifications</b>	<b>11</b>
<b>3. Preparations before Use</b>	<b>12</b>
3-1) Power Connection	12
3-2) Changing Power Voltage	13
3-3) Setting Main Shaft Motor Type	13
<b>4. SM Operation 1 (Basic)</b>	<b>14</b>
4-1) Names and Functions of Keys in the Operation Box	14
4-2) Setting Item Data	15
4-3) Checking Pattern Shape	17
4-4) Sewing	17
4-5) Changing Sewing Pattern	18
4-6) Lower Thread Winding	18
4-7) Emergency Stop During Sewing (for GPS-0504)	18
<b>5. SM Operation 2 (Advanced)</b>	<b>19</b>
5-1) User Program	19
5-2) Sewing using Combination Function	20
5-3) Sewing using Lower Thread Counter	21
5-4) Precautions	22
<b>6. Using Memory Switch</b>	<b>23</b>
6-1) Memory Switch Operation	23
6-2) Example of Memory Switch Set-up	23
6-3) Memory Switch Functions Table	27

<b>7. Maintaining/Repairing</b>	<b>30</b>
7-1) Cleaning C/B	30
7-2) Replacing Fuse	30
7-3) Testing the Machine	31
7-4) Other Functions	34
7-5) Installing and Replacing ROM	35
7-6) Pattern download from PDA (or PC)	40
7-7) Pattern download from CF card	41
<b>8. Error List</b>	<b>43</b>
<b>9. How Select the Sewing Pattern List and the Sewing Lange</b>	<b>46</b>
9-1) GPS-0402 Series	46
9-2) GPS-0402 BS Series	47
9-3) GPS-0504 Series	48
<b>10. BASIC MANUAL</b>	<b>50</b>

# 1

## Machine Safety Regulations



Safety instruction on this manual are defined as Danger, Warning and Caution.

If you do not keep the instructions, physical injury on the human body and machine damage might be occurred.

**Caution** : When the machine is improperly handled, user injury or physical damage to the machine is expected to occur.

**Warning** : When the machine is improperly handled, critical injury or death of a user is expected to occur.

**Danger** : When the machine is improperly handled, critical injury or death of a user is expected to occur, and the high-level of emergency situation would like to happen.

<p><b>1-1) Machine Transportation</b></p> 	<p>Those in charge of transporting the machine should know the safety regulations very well. The following indications should be followed when the machine is being transported.</p> <ul style="list-style-type: none"> <li>Ⓐ More than 2 people must transport the machine.</li> <li>Ⓑ To prevent accidents from occurring during transportation, wipe off the oil on the machine well.</li> </ul>
<p><b>1-2) Machine Installation</b></p> 	<p>The machine may not work well or breakdown if installed in certain places. Install the machine where the following qualifications agree.</p> <ul style="list-style-type: none"> <li>Ⓐ Remove the package and wrappings starting from the top. Take special notice on the nails on the wooden boxes.</li> <li>Ⓑ Dust and moisture stains and rusts the machine. Install an airconditioner and clean the machine regularly.</li> <li>Ⓒ Keep the machine out of the sun. If the machine is exposed in direct ray of light for a long time, transformation of color and shape can be happened.</li> <li>Ⓓ Leave sufficient space of more than 50cm behind, and on the right, left and back side of the machine for repairing.</li> <li>Ⓔ Do not operate in explosive atmospheres. To avoid explosion, do not operate this machine in an explosive atmosphere including a place where large quantities of aerosol spray product are being used or where oxygen is being administered unless it has been specifically certified for such operation.</li> <li>Ⓕ The machine were not provided with alocal lighting due to the feature of machine. Therefore the illumination of the working area must be fulfilled by end user.</li> </ul> <p>[Refer] Details for machine installment are described in 4. Machine Installment.</p>
<p><b>1-3) Machine Repair</b></p> 	<p>When the machine needs to be repaired, only the assigned troubleshooting engineer educated at the company should take charge.</p> <ul style="list-style-type: none"> <li>Ⓐ Before cleaning or repairing the machine, close down the motive power and wait 5 minutes till the machine is completely out of power.</li> <li>Ⓑ Not any of the machine specifications or parts should be changed without consulting the company. Such changes may make the operation dangerous.</li> <li>Ⓒ Spare parts produced by the company should only be used for replacements.</li> <li>Ⓓ Put all the safety covers back on after the machine has been repaired.</li> </ul>



### 1-4) Machine Operation



C(D) Bartack Series is made to sew patterns on fabrics and other similar material for manufacturing. Follow the following indications when operating the machine.

- Ⓐ Read through this manual carefully and completely before operating the machine.
- Ⓑ Wear the proper clothes for work.
- Ⓒ Keep hands or other parts of the body away from the machine operation parts(needle, shuttle, thread take-up lever, and pulley etc.) when the machine is being operated.
- Ⓓ Keep the covers and safety plates on the machine during operation.
- Ⓔ Be sure to connect the earthing conductor.
- Ⓕ Close down the electric motive power and check if the switch is turned "off" before opening electric boxes such as the control box.
- Ⓖ Stop the machine before threading the needle or checking after work.
- Ⓗ Do not step on the pedal when turning the power on.
- Ⓘ Do not use several motor per a electric outlet.
- Ⓚ If possible, install the machine away from loud noise such as high frequency welding machines
- Ⓛ Be careful when the upper feed plate comes down to press. Otherwise, the finger or hand height be hurt at smacking.



**Warning**





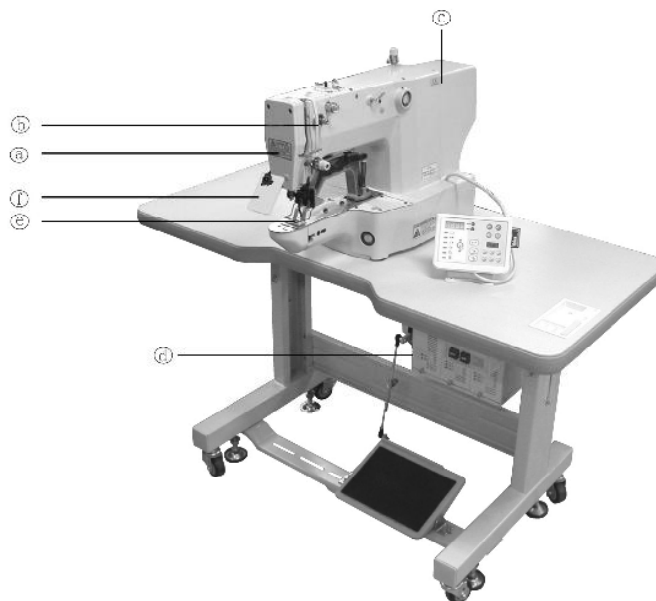

- 1) Make sure that the cover is in place, while the machine is operating. Otherwise, the belt might injure or cut a finger.
- 2) Make sure that the power is turned "OFF" before examining or adjusting the machine.

### 1-5) Devices for Safety



- Ⓐ Safety label : It describes cautions during operating the sewing machine.
- Ⓑ Thread take-up cover : It prevents from any contact between body and take-up lever.
- Ⓒ Motor cover(B, D series) : It prevents from accidents during rotation of motor.  
Belt cover(A, C series) : It prevents from accidents during rotation of belt.
- Ⓓ Label for specification of power : It describes cautions for safety to protect against electric shock. (Voltage and Hz)
- Ⓔ Finger guard : It prevent from contacts between a finger and needle.
- Ⓕ Safety plate : It protects eyes against needle breaks.



<p><b>1-6) Caution Mark Position</b></p> <div data-bbox="156 427 432 674">  <p><b>CAUTION</b> 경고</p> <p>Do not operate without finger guard and safety devices. Before threading, changing bobbin and needle, cleaning etc. switch off main switch. 손가락 보호대와 안전장치 없이 작동하지 마십시오. 실, 보빈, 바늘교환시나 청소전에는 반드시 주전원의 스위치를 꺼 주십시오.</p> </div> <div data-bbox="156 797 432 1021">  <p><b>WARNING</b> 경고</p> <p>Hazardous voltage will cause injury. Be sure to wait at least 360 seconds before opening this cover after turn off main switch and unplug a power cord. 고압 전류에 의해 감전될 수 있으므로 커버를 열 때는 전원을 내리고 전원 플러그를 뽑고 나서 360초간 기다린 후 여십시오.</p> </div>	<p>Caution mark is attached on the machine for safety. When you operate the machine, observe the directions on the mark.</p> <p>Position of Warning Mark</p> 
<p><b>1-7) Contents of Marks</b></p> <div data-bbox="236 1350 347 1491">  <p>Warning</p> </div>	<p><b>Caution</b></p> <p>1)</p> <div data-bbox="692 1290 1169 1630">  <p><b>CAUTION</b> 경고</p> <p>Do not operate without finger guard and safety devices. Before threading, changing bobbin and needle, cleaning etc. switch off main switch. 손가락 보호대와 안전장치 없이 작동하지 마십시오. 실, 보빈, 바늘교환시나 청소전에는 반드시 주전원의 스위치를 꺼 주십시오.</p> </div> <p>2)</p> <div data-bbox="692 1675 1169 2016">  <p><b>WARNING</b> 경고</p> <p>Hazardous voltage will cause injury. Be sure to wait at least 360 seconds before opening this cover after turn off main switch and unplug a power cord. 고압 전류에 의해 감전될 수 있으므로 커버를 열 때는 전원을 내리고 전원 플러그를 뽑고 나서 360초간 기다린 후 여십시오.</p> </div>

# 2

## Electronically Controlled Bartacking SM Specifications

Model	GPS-0402 H	GPS-0402 M	GPS-0402 L	GPS-0402 K	GPS-0402 H-10
Subject Materials	Heavy	General	Light	Knitwear	Pneumatic
Sewing Scope (X,Y)	X : 40mm      Y : 20 mm				
Maximum Speed	Max 2,700spm		Max 2,000spm		Max 2,200spm
Stitch Width	0.1 ~ 10 mm				
Needle	DP×17 #19	DP×5 #16	DP×5 #11		DP×17 #23
Hook	Standard shuttle hook				
Presser foot height	Max 17 mm				Max 20mm
Thread Trimmer	★				
Wiper	★				Optional
Lower Thread Counter	★				
Memory	P-ROM				
Shuttle	Half rotation standard hook				
Max Speed Limit	Up to 100 ~ 2,700 spm with an external switch				
Needle Bar Stroke	41.2mm				
Default Patterns	32 patterns				
Maximum Patterns	Maximum 99 patterns (default 32 + 67 additional)				
Maximum Stitches	Maximum 10,000 stitches				
Scale Scope	20 ~ 200 % (adjustable by 1%)				
Motor Specification	550W AC servo motor (standard power: 600 W)				
Drive System	Pulse motor				
Optimal Temperature	5° C ~ 40° C				
Optimal Humidity	20% ~ 80%				
Air Pressure					0.49Mpa (5kgf/cm <sup>2</sup> )
Power	Single-phase : 100~240V, 3-phase : 200~440V, 50/60Hz				

# 3

## Preparations before Use

### 3-1) Power Connection

- Voltage Specification

Voltage information is tagged on the power plug as indicated below.

이 기계의 전기 사양은 공장 출고 시 아래의  V 표기되로 결선되어 있습니다.  
The Electric Specification of This Machine is Connected Under  V Marked.

V 단상 (1 Phase)                       V 삼상 (3 Phase)

110V  120V  220V  240V  220V  240V

1. Do NOT use the machine with different voltage specification.
2. Please refer to 『Changing Power Voltage』 section before changing the voltage.

- Single phase connection (100V, 110V, 120V, 200V, 220V, 240V)
- 3-phase connection (200V, 220V, 240V, 380V)

 <b>Caution</b>	<b>In case of 3-phase 380V, it is necessary to install an additional trans box on the table (check it out upon making a purchase order).</b>
---	--

### 3-2) Changing Power Voltage

- Use SMPS to maintain constant voltage when changing the input voltage.
- This machine adopts a free voltage system. Use the voltage connector to set voltage status of the main shaft board at 110V or 220V according to the input voltage.



**Caution**

**Incorrect setting of the voltage connector may damage the control box.**

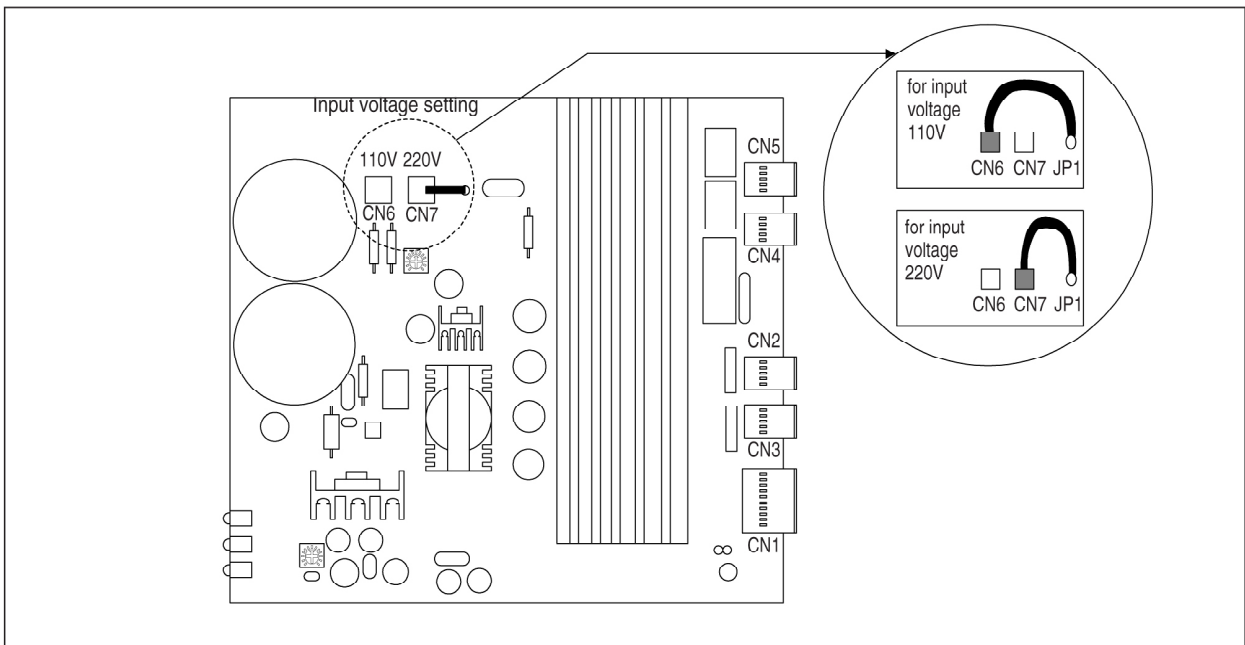

### 3-3) Setting Main Shaft Motor Type

- Digital board must be set to dip switch according to the main shaft motor type.

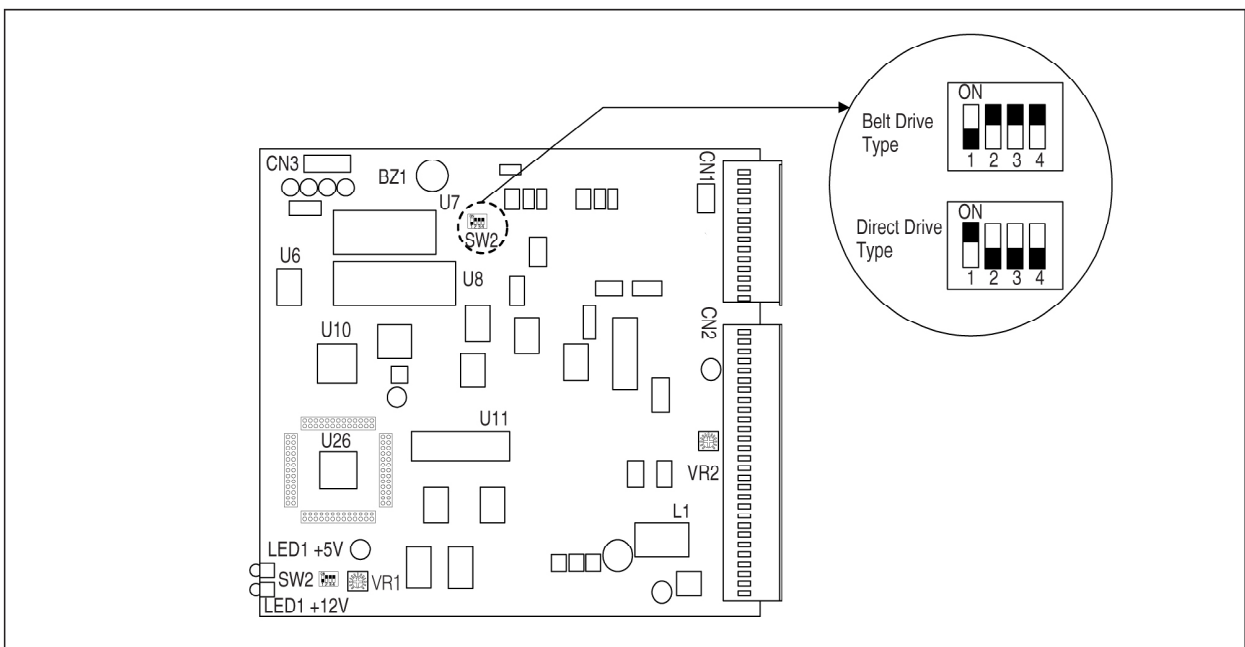

# 4

## SM Operation 1 (Basic)

### 4-1) Names and Functions of Keys in the Operation Box

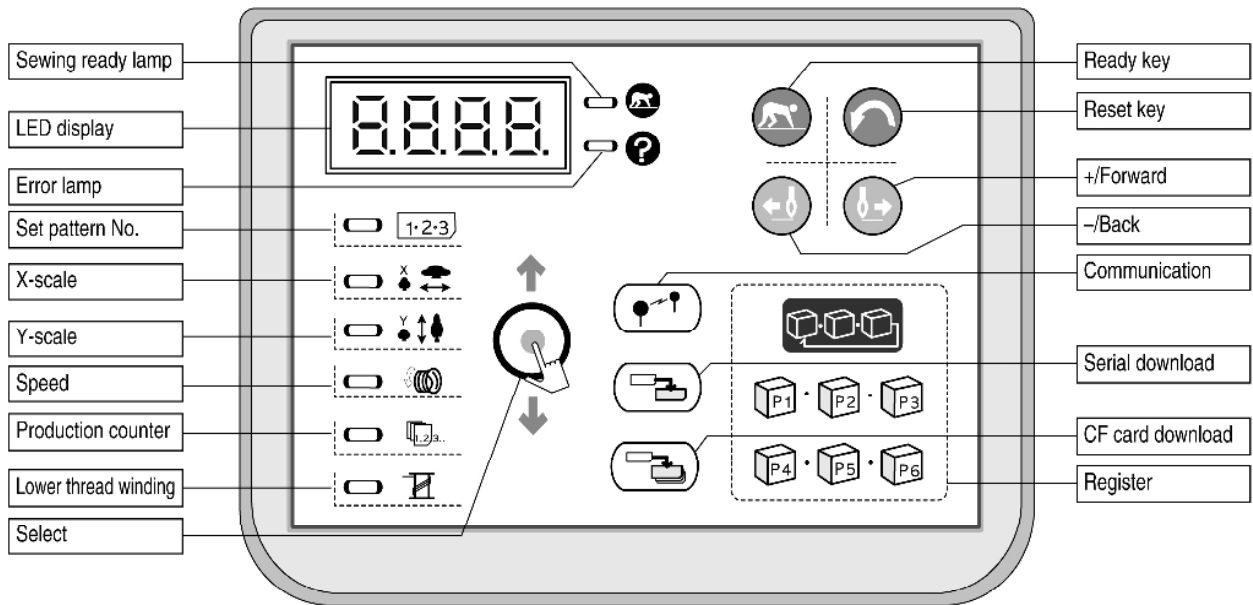

※ Previous pattern number will appear when you turn on the power.  
Refer to the following functions of LED and keys.

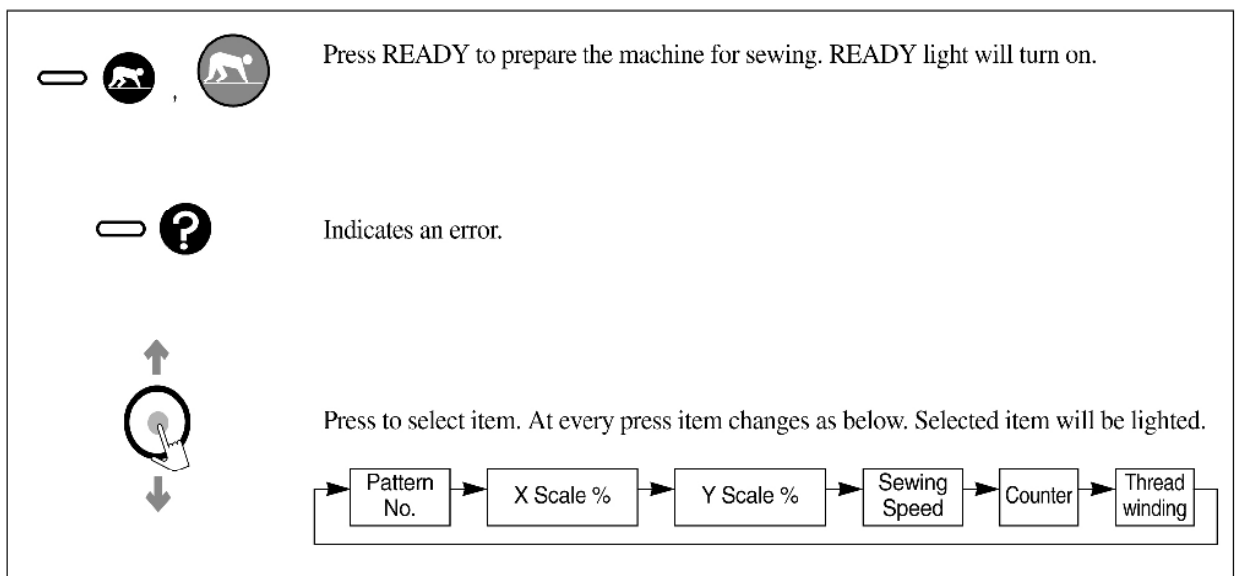

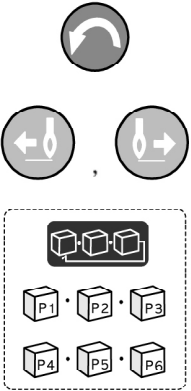

Press to set the machine back to the default value.

Press to increase/decrease the set value or to move the needle bar backward or forward.

One click to call a certain pattern.



**Caution**

- 1) For direct connection type, if the head is laid down on the side while the power is on, "oPEn" will appear. If READY key is on at this time, sewing does not start with your pedaling.
- 2) If the head is laid down on the side while sewing, "oPEn" will not appear until sewing is completed.

## 4-2) Setting Item Data

You can set each item in the following order.

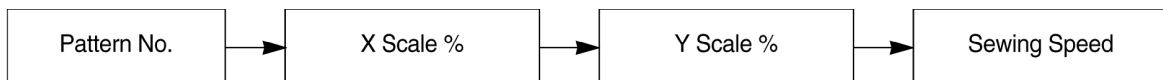

A. Turn on the power.

Item "Pattern No." will lit up and the previous pattern number will appear.

B. Set the pattern number.

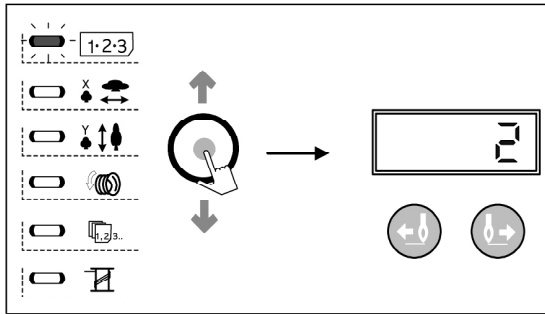

- 1) Press **SELECT** to display NO.
- 2) Press **+ / FORWARD**, **- / BACK** to display "2" on the screen (setting pattern No.2).

※ Refer to the program list.

C. Set X Scale %.

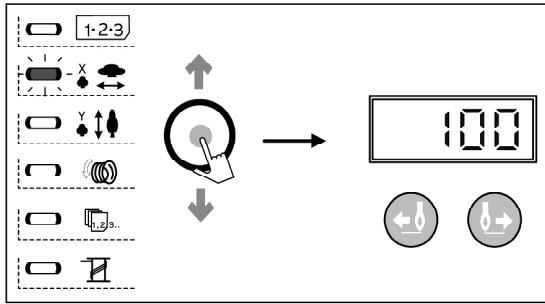

- 1) Press **SELECT** to display item "X-Scale".
- 2) Press **+ / FORWARD**, **- / BACK** to set within the range of 20%~200%.

D. Set Y Scale %

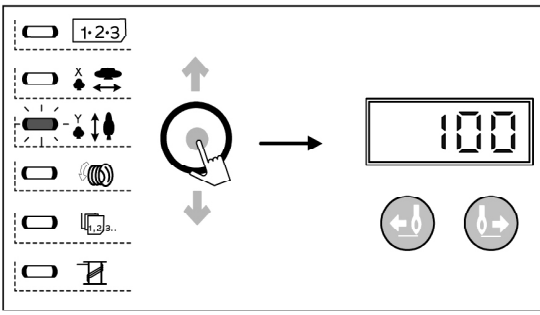

- 1) Press **SELECT** to display item “Y-Scale”.
- 2) Press **+ / FORWARD**, **- / BACK** to set within the range of 20%~200%.

E. Set Sewing Speed

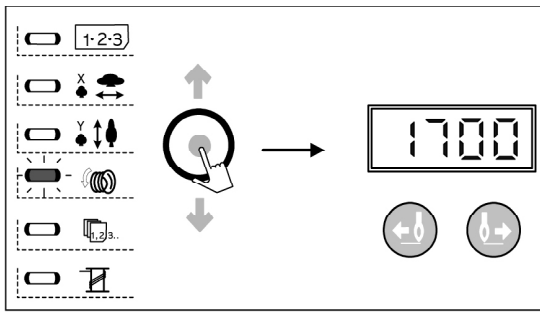

- 1) Press **SELECT** to display item “Speed”.
- 2) Press **+ / FORWARD**, **- / BACK** to set the speed at 1700.

F. Setting Done

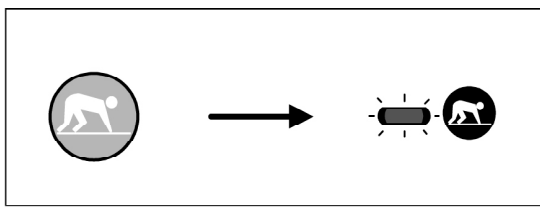

- 1) Press **READY**.
- 2) Presser plate will move/lift and READY light will be on. The machine will be on standby
- ※ You can press **SELECT** to confirm the setting.

 <b>Caution</b>	<p><b>Check the pattern number before starting the machine.</b></p> <p>1) If <b>READY</b> is pressed with the pattern number “0” (default status), the machine will move back to original point. Use it to check the machine original point.</p> <p>2) If you select a pattern that contains no data, error “Er01” will appear. Select other pattern.</p>
---	---

G. Threading (for GPS-0504)

Press EMERGENCY STOP switch in the **READY** status. Upper feed plate and presser foot will descend.  
 Press EMERGENCY STOP switch again to lift the upper feed plate and presser foot.



### 4-3) Checking Pattern Shape

**Caution**

1) Make sure to check the pattern shape after selecting pattern number.  
**If pattern goes beyond the driving limit of the presser plate, needle and presser plate may conflict during sewing and result in serious problems, i.e. needle break.**

2) Do NOT pedal 2nd step while checking the pattern shape. 2nd step pedaling starts sewing.

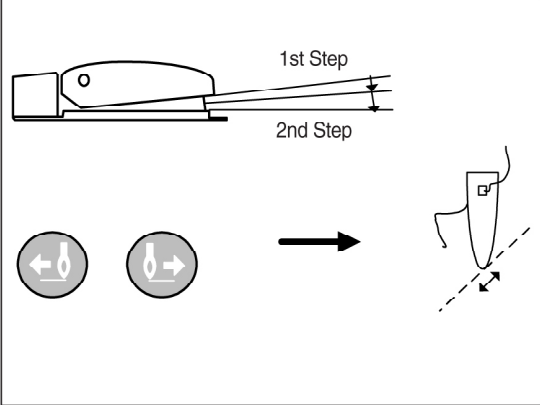

- 1) In READY status, press pedal 1st step to bring down the presser plate.
- 2) The presser plate moves by one stitch at every press of **+/FORWARD** or **-/BACK**. Press down the keys to move the plate continuously.
- 3) Press **RESET** to move the needle to the starting point. The presser plate will move up.

◀ CAUTION ▶  
 Take your foot off the pedal when the needle starts to move (even a stitch).

### 4-4) Sewing

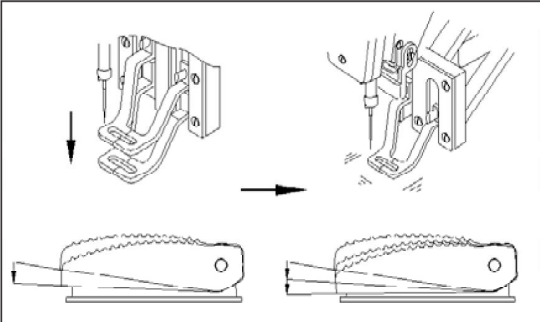

- 1) Place the work material on the presser plate.
- 2) Pedal 1st step to bring down the presser plate. Take your foot off the pedal to lift the plate.
- 3) Pedal 2nd step with the presser plate down and the sewing will start.
- 4) When the sewing is completed, presser plate will go up and move to the sewing starting point.

#### ■ 2-step pedal switch interconnection

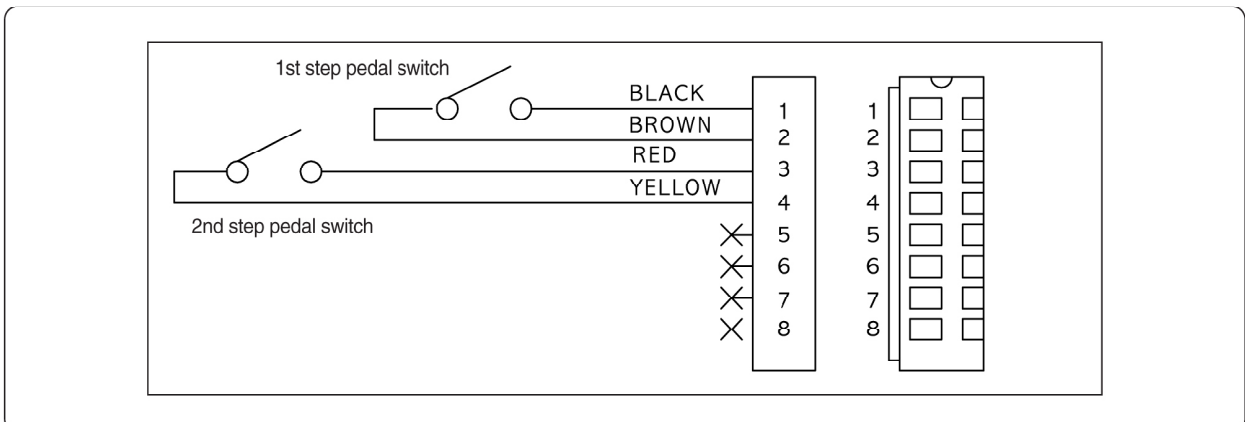

• 1st step pedaling: clamp function

• 2nd step pedaling: sewing starts

#### 4-5) Changing Sewing Pattern

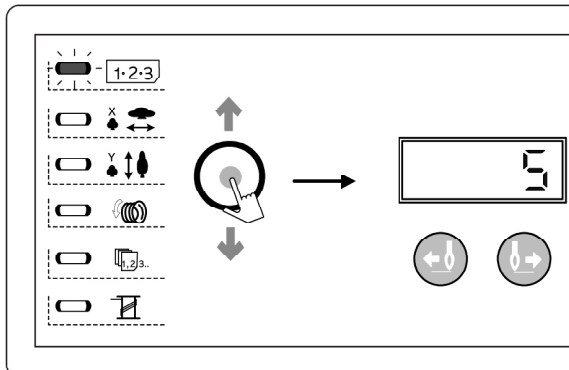

- 1) Press **READY** (READY light will turn off).
- 2) Press **SELECT** to display item “NO”.
- 3) Set (B) ~ (F) items in 4-2 and move to the item of checking pattern shape.

#### 4-6) Lower Thread Winding

##### A. Lower thread winding while sewing



Thread as shown in the picture and wind the lower thread.

##### B. Lower thread winding only



**Caution**

During lower thread winding, the feed plate does not move but the needle moves. Therefore, make sure no object is under the needle during the winding.

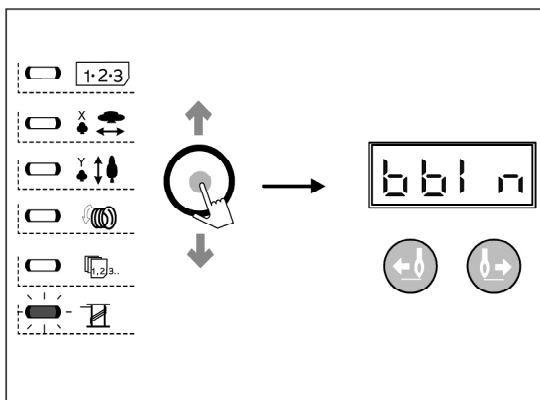

- 1) Press **SELECT** to select the item “WINDER” .  
※ If READY is on, WINDER is not selected.
- 2) Press **READY**.
- 3) Press the pedal switch to 2nd step.  
Bobbin winder will start to wind.
- 4) Press the pedal switch to 2nd step again. Winding will stop.
- 5) Press **READY** to end winding.

#### ◀ CAUTION ▶

When using hole fixing device, if you shift to bobbin winding mode and press **READY**, the pin hole will go down and the presser plate will move to the original point.

#### 4-7) Emergency Stop During Sewing (for GPS-0504)

Pressing EMERGENCY STOP during sewing will stop at present position. Press FORWARD/BACK to move the feed plate stitch by stitch. If you want to stop the sewing work altogether, press EMERGENCY STOP again. If you want to re-start the sewing at the stopped position, press the pedal again.

# 5

## SM Operation 2 (Advanced)

### 5-1) User Program

You can register and use 26 different programs (P1-P26) as user programs.  
The 26 user programs can hold information, i.e. pattern number, X scale %, Y scale %, and sewing speed.  
It will be convenient for you to register repeatedly used patterns in the user program.

#### (1) Registering the User Program

Ex) Registering the following set-up as P1.

Pattern Number 3  
X scale %: 50%  
Y scale %: 80%  
Maximum speed limit: 1800spm

- A. Press **[SELECT]** and turn on the power.
- B. Press **[P1]**.
- C. Press **[SELECT]** to display number items  
Press **[+/FORWARD]**, **[-/BACK]** to set the pattern number at 3.
- D. Press **[SELECT]** and use **[+/FORWARD]**, **[-/BACK]** to set the X scale % at "50%" and Y scale % at "80%" and the maximum speed limit at "1800 spm".
- E. Press **[READY]** to end registration.  
※ To register P2-P26, press P2-P26 in B of the above and follow the rest of the procedures.
- F. After registration, turn off the power and turn it on again.

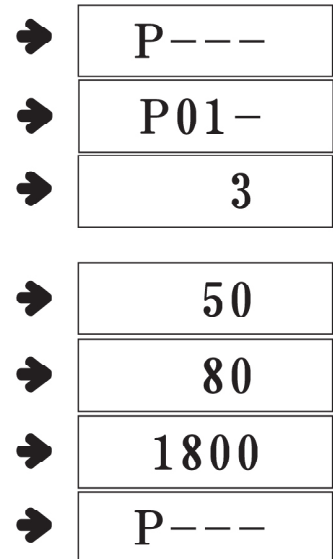

#### (2) Selecting the User Program

Reg. No.	Key(s)	Reg. No.	Key(s)	Reg. No.	Key(s)	Reg. No.	Key(s)
P01	[P1]	P08	[P1] + [P3]	P15	[P2] + [P6]	P22	[P1] + [P2] + [P3]
P02	[P2]	P09	[P1] + [P4]	P16	[P3] + [P4]	P23	[P1] + [P2] + [P4]
P03	[P3]	P10	[P1] + [P5]	P17	[P3] + [P5]	P24	[P1] + [P2] + [P5]
P04	[P4]	P11	[P1] + [P6]	P18	[P3] + [P6]	P25	[P1] + [P2] + [P6]
P05	[P5]	P12	[P2] + [P3]	P19	[P4] + [P5]	P26	[P4] + [P5] + [P6]
P06	[P6]	P13	[P2] + [P4]	P20	[P4] + [P6]		
P07	[P1] + [P2]	P14	[P2] + [P5]	P21	[P5] + [P6]		



**Caution**

By default, P1-P26 contain information of pattern number 1, X & Y scale 100%, and speed 1500.  
To not display P1-P26 mark when scrolling the pattern numbers, set the pattern number "0" in C of the above procedures.

### (3) Sewing Operation

Ex) Do sewing work according to P1 and then according to P3.

A. Turn on the power.

B. Press **[P1]**.

C. Press **[READY]**. READY lamp will turn on and feed plate will move and go up.

D. Check the pattern shape (refer to <Checking Pattern Shape> section).

E. After checking, you can start sewing.

F. After sewing is completed, press **[P3]**. Feed plate will search the original point and move to the starting point.

(You can change the pattern with a short key (single press) even with the READY lamp on).

G. Perform D and E of the above procedures.

※ P1-P26 will be displayed when changing pattern using **[+/FORWARD]** or **[-/BACK]**.

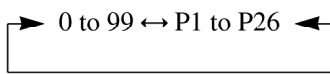

Unregistered programs will not be displayed.

## 5-2) Sewing using Combination Function

You can list the pre-registered user programs (P1-P26) in Cnb1 and Cnb2 and change the pattern in the order of the programs on the list.

※ Maximum number of program combinations you can register in Cnb1 and Cnb2 is 30.

### (1) Registration of Combinations

Ex) Combine P1, P2, and P3 (in that order) and register the combination in Cnb1. ➔

A. Turn on the power pressing **[P1]** and **[SELECT]**. ➔

B. Press **[SELECT]** and then **[P1]**. ➔

C. Press **[SELECT]** and then **[P2]**. ➔

D. Press **[SELECT]** and then **[P3]**. ➔

E. Press **[READY]** to complete the registration. ➔

F. Turn off the power and turn it on again.

※ To register in Cnb2, press **[P2]** and **[SELECT]** in A of the above procedure.

Cnb1

01.01

02.02

03.03

Cnb1



Caution

Patterns that are not registered with function keys (P1-P26) cannot be combined.

## (2) Sewing Operation

- A. Turn on the power.
- B. Change the pattern number using **[+/FORWARD]** or **[-/BACK]**. At every press, the pattern number will change as shown below. Scroll down to change.

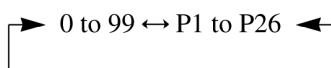

※ Unregistered P1-P26 and Cnb1-Cnb2 are not displayed.

- C. Press **[READY]**. READY lamp will be lit and feed plate will move and go up.
  - D. Check the pattern shape and start sewing.
  - E. Sewing stages are formed according to the combination. Sewing will return to the first stage after each cycle is completed. Sewing will be done repeatedly.
- ※ ① If you want to go to the previous or the next pattern, press **[+/FORWARD]** or **[-/BACK]** while READY lamp is on. Number will be changed and the feed plate will move to the starting point.
  - ※ ② P1-P26 in Cnb1-Cnb2 will change if patterns in P1-P26 have been changed after registration in Cnb1-Cnb2.
  - ※ ③ Make sure to check each pattern shape (refer to 『Checking Pattern Shape』 section).
  - ※ ④ The machine will automatically shift to the next pattern within the combination (for example Cnb1).



Caution

If you undo READY and press RESET during the combination sewing, you will move to the initial state of the selected combination.

## 5-3) Sewing using Lower Thread Counter

Workload counter can also be used as a lower thread counter. If you are repeating the same pattern, the machine will stop when it reaches the sewing limit of one bobbin. At this time, the lower thread counter should be set at reduction mode.



Caution

The counter is set as a workload counter (addition mode) as default. To set the counter as a lower thread counter, you need to change the memory switch (refer to 『Using Memory Switch』).

- A. Press **[SELECT]** with the READY light off. "COUNTER" will be displayed.
- B. Press **[RESET]**.
- C. Set the sewing limit of a single bobbin, using **[+/FORWARD]** and **[-/BACK]**.
- D. The counter value will drop by 1 after each sewing is completed.
- E. When you sewed to the set limit, the machine will not sew even you pedal.
- F. Replace the bobbin and press **[RESET]**.
- G. Repeat (D) ~ (F).

## 5-4) Precautions

- A. Make sure to thread and sew after the thread tension plate is shut. The plate opens after trimming.
- B. If error lamp turns on, investigate the cause and take appropriate actions.
- C. Do not pull the sewing fabric, while sewing is conducted. The needle position might be improperly changed.  
In the case of needle position distortion, press **READY** twice to bring the needle to the right position.
- D. Do NOT turn off the power with the needle bar down.

### ■ Sewing speed for different work

	Sewing speed (SPM)
Denim 8 sheets	2,200 ~ 2,700
Denim 12 sheets	2,200 ~ 2,500
Clothes	2,200 ~ 2,700
Clothes (artificial thread)	2,000 ~ 2,300
Knit	1,800 ~ 2,000
Underwear	1,800 ~ 2,000

- E. Set the sewing speed according to the above table in order to prevent thread break from heat.
- F. For materials like underwear, lower the needle bar height in order to prevent jump stitch (refer to <Adjusting Needle Bar Height>).

# 6

## Using Memory Switch

### 6-1) Memory Switch Operation

The memory switch has two major functions: general sewing function (changing general operation) and servo motor controlling function (changing servo motor operation).

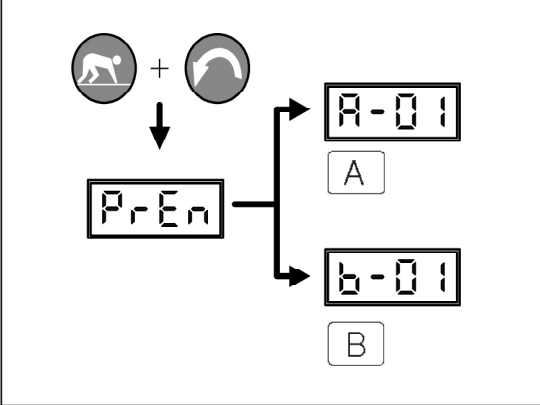

- 1) Turn on the power pressing **READY** and **RESET**.
- 2) For changing general sewing-related functions, press **A**.
- 3) For changing servo motor control-related functions, press **B** and operate the memory switch.

※ Turn off the power and back on again after changing the memory switch set-up.

### 6-2) Example of Memory Switch Set-up

#### (1) Setting maximum sewing speed

A Turn on the memory switch and press <b>+ / FORWARD</b> . You will see "A-01" on the screen.	➔ <span style="border: 1px solid black; padding: 5px 20px; font-family: monospace;">A - 01</span>
B. Press <b>READY</b> and you will see the present set-up.	➔ <span style="border: 1px solid black; padding: 5px 20px; font-family: monospace;">2000</span>
C. Press <b>- / BACK</b> to change the set-up value to 1800.	➔ <span style="border: 1px solid black; padding: 5px 20px; font-family: monospace;">1800</span>
D. Register the set-up value by pressing <b>READY</b> .	➔ <span style="border: 1px solid black; padding: 5px 20px; font-family: monospace;">A - 01</span>

## (2) Setting Softstart Speed

You can change the speed for the first 1-5 stitches by 100 spm.

	Scope	Default
1st stitch	400 ~ 900	400 spm
2nd stitch	400 ~ 2700	900 spm
3rd stitch	400 ~ 2700	2,300 spm
4th stitch	400 ~ 2700	2,300 spm
5th stitch	400 ~ 2700	2,300 spm

- The above values may not be the same for all machine types. (above is for M and H types)



Caution

For the maximum rotation number, general sewing function No. A-01 (maximum sewing speed) applies first.

Ex) Changing the 1st stitch 400→900 rpm and the 2nd stitch 900→1,200 rpm

A. Turn on the memory switch and press **+FORWARD** to display “A-02” on the screen.



A - 02

B. Press **READY** to display the present set-up value (1st stitch speed: 400 spm).



1 - 04

C. Press **+FORWARD** to change to “1-09” (changing to 900 spm).



1 - 09

D. Press **SELECT** (2nd stitch speed 900spm is displayed).



2 - 09

E. Press **+FORWARD** to change to “2-12” (changing to 1,200 spm)



2 - 12

F. Register the set-up using **READY**.



A - 02



### (3) Setting Pattern Data Call Function

You can inactivate calling unnecessary patterns. This prevents calling wrong patterns by mistake and helps you call the necessary patterns.

Ex) Inactivating calling of patterns 1 and 2

A. Turn on the memory switch and press <b>+ / FORWARD</b> to display "A-03" on the screen.	➔	<b>A - 03</b>
B. Press <b>READY</b> to display the present set-up value. Ⓐ part : pattern number Ⓑ part : 0 :calling impossible 1 :calling possible	➔	<b>01 - 1</b> Ⓐ       Ⓑ
C. Press <b>- / BACK</b> to change "1" in Ⓑ to "0".	➔	<b>01 - 0</b>
D. Press <b>SELECT</b> to change "1" in Ⓐ to "2"	➔	<b>02 - 1</b>
E. Press <b>- / BACK</b> to change "1" in Ⓑ to "0".	➔	<b>02 - 0</b>
F. Register the set-up using <b>READY</b> .	➔	<b>A - 03</b>

### (4) Setting the Counter Function

Ex) Changing production counter (addition mode) to lower thread counter (reduction mode)

A. Turn on the memory switch and press <b>+ / FORWARD</b> to display "A-05" on the screen.	➔	<b>A - 05</b> Ⓐ
B. Press <b>READY</b> to display the present set-up value.	➔	<b>0</b>
C. Press <b>+ / FORWARD</b> to set "05-1". Ⓐ part : 0 : production counter 1 : lower thread counter	➔	<b>1</b>
D. Register the set-up using <b>READY</b> .	➔	<b>A - 05</b>

(5) Selecting Upper Thread Holding Function

For pneumatic type, if you want to use an upper thread holding function, change the parameter as below.

A. Turn on the memory switch and press <b>+FORWARD</b> to display “A-32” on the screen.	➔	<b>A - 32</b> Ⓐ
B. Press <b>READY</b> to display the present set-up value. Ⓐ part : 0 : holding device OFF 1 : holding device ON	➔	<b>0</b>
C. Press <b>+FORWARD</b> to change Ⓐ “0” to “1”	➔	<b>1</b>
D. Register the set-up using <b>READY</b> .	➔	<b>A - 32</b>

(6) Selecting between Integrated/Separated Pedals

For pneumatic type, if you want to use a separated pedal, change the parameter as below.

Ex) Using a separated pedal

A. Turn on the memory switch and press <b>+FORWARD</b> to display “A-33” on the screen.	➔	<b>A - 33</b> Ⓐ
B. Press <b>READY</b> to display the present set-up value. Ⓐ part : 0 : integrated pedal 1 : separated pedal	➔	<b>0</b>
C. Press <b>+FORWARD</b> to change Ⓐ “0” to “1”.	➔	<b>1</b>
D. Register the set-up using <b>READY</b> .	➔	<b>A - 33</b>

 <b>Caution</b>	<b>To use a separated pedal as an integrated pedal, press <b>-BACK</b> between step B and step C and change Ⓐ “1” to “0.” Then register the change using <b>READY</b>.</b>
---	--

## 6-3) Memory Switch Functions Table

### (1) General sewing functions (A Group)

Turn on the power pressing  and . Turn on the memory switch pressing **PI**.

No.	Functions and Description	Scope	Default	Unit	
A-01	Setting maximum sewing speed	General: 100 ~ 2,700 Heavy: 100 ~ 2,700 Light: 100 ~ 2,000 Knitwear: 100 ~ 2,000 Pneumatic: 100 ~ 2,200 Buttons: 100 ~ 2,500 Pattern taker: 100 ~ 2,500	2,300 spm 2,300 spm 1,800 spm 1,800 spm 1,800 spm 2,300 spm 2,200 spm	100spm	
A-02	Setting speed for the first 1-5 stitches (Softstart function, different by type)	1st stitch: 400-900 2nd stitch: 400~2,000 3rd stitch: 400-2,000 4th stitch: 400~2,000 5th stitch: 400~2,000	400 spm 900 spm 2,300 spm 2,300 spm 2,300 spm	100spm	
A-03	Setting pattern data calling (You can set for each pattern)	0 : calling impossible 1 : calling possible	1201 1~22 : 1 23~99 : 0	1202 1~33 : 1 34~99 : 0	1254 1~56 : 1 57~99 : 0
A-04	Setting display and change possibility of X,Y scale rate and maximum speed limit (prevent errors or mistakes)	0 : change impossible 1 : change possible	1		
A-05	Setting counter function Production counter : addition count Lower thread counter : reduction count	0 : production counter 1 : lower thread counter	0		
A-06	Setting center point for scale	0 : original point 1 : sewing start point	0		
A-07	Setting whether to search original point after sewing (sewing with ordinary pattern number)	0 : OFF 1 : ON	0		
A-08	Setting whether to search original point after sewing (sewing with function combination)	0 : OFF 1 : ON	0		
A-09	Setting drive scope to infinite	0 : Infinite 1 : limited	1		
A-10	Setting starting angle for X, Y drive	-100 ~ 100°	Belt type : 0° , Direct : -24°	1°	
A-11	Setting trimming speed	200 ~ 400spm	400 spm	100spm	
A-12	Setting reverse rotation after trimming	0 : OFF, 1 : ON	0		
A-13	Setting angle for reverse rotation after trimming	0~70°	0°	1°	
A-14	Setting whether to use electronic wiper	0 : OFF 1 : ON	1201, 1202 0	1254 1	
A-15	Faster moving of presser foot after trimming	0 : OFF, 1 : ON	1		
A-16	Setting search for original point after certain amount of sewing (after amount set in A-17)	0 : OFF 1 : ON	0		
A-17	Number of automatic search for original point	0~1000	1000	4	
A-18	Time for electronic wiper ON	4~1024 ms	100 ms	4 ms	
A-19	Canceling trimming	0 : trim ON 1 : trim OFF	0		
A-20	Time for solenoid 0 full on (clamp solenoid)	4~72 ms	52 ms	4 ms	
A-21	Time for solenoid 1 full on (trimming solenoid)	4~1020 ms	100 ms	4 ms	
A-22	Time for solenoid 2 full on (sub solenoid 2)	4~1020 ms	100 ms	4 ms	
A-23	Time for solenoid 3 full on (sub solenoid 3)	4~1020 ms	100 ms	4 ms	
A-24	Solenoid 0 duty (clamp solenoid)	10~25%	10%	1%	
A-25	Solenoid 1 duty (trimming solenoid)	10~25%	20%	5%	
A-26	Solenoid 2 duty (sub solenoid 2)	10~25%	20%	5%	
A-27	Solenoid 3 duty (sub solenoid 3)	10~25%	20%	5%	
A-28	Delay time for clamp solenoid moving up	4~1020 ms	Pneumatic 100 ms	Others 500 ms	4 ms
A-29	Delay time for clamp solenoid moving down		Others 40 ms	Hole fix device 100 ms	
A-30	Setting OFF time for electronic wiper	4~1020 ms	Others 40 ms	Hole fix device 100 ms	4 ms
A-31	Setting whether clamp moves up/down after mid trimming	0 : Down, 1 : Up	1		
A-32	Setting pneumatic thread holder	0 : OFF, 1 : ON	0		
A-33	Setting integrated/separated pedal (For pneumatic only. Others have integrated pedals)	0 : integrated 1 : separated	0		
A-34	Setting whether to use pin hole device	0 : OFF 1 : ON	Others 0	Hole fix device 1	
A-35	Setting whether to use head open/close	0 : OFF 1 : ON	Only in Direct type 1		
A-36	Whether to use upper stop when turn power on	0 : OFF 1 : ON	Only in Direct type 1		
A-37	Set time for AC off checking	4 ~ 48 [ms]	20 ms		
A-38	Set time for voltage overload checking	4 ~ 1024 [ms]	20 ms		

## (2) Servo Motor Control Functions (B Group)

Turn on the power pressing  and . Turn on the memory switch pressing **[P2]**.

No.	Functions and Descriptions	Function Name	Scope	Default			Unit / Reference
				Fortuna III	Forturn IV	Sanyo	
B-01	Speed for location detection for stop	pos_spd	2-510	220	400	400	2spt
B-02	Speed immediately before stop	end_spd2	0~255	16	50	50	1spt
B-03	Delay time to stop at right position	StopDelay	4-1020	80	20	20	4ms
B-04	First distance of location detection	DIST1	0~255	150	50	50	1Pulse
B-05	Speed P-Gain	KC1A	0~1000	20	15	30	1
B-06	Not used	-	-	-			-
B-07	Speed D-Gain	KC1C	0~1000	0	15	0	1
B-08	Not used	-	-	-			-
D-09	Position P-Gain	KF1A	0~1000	175	125	150	1
B-10	Not used	-	-	-			-
B-11	Position D-Gain	KF1C	0~5000	1500	1750	700	1
B-12	Speed unit	spd_unit	1~255	100rpm			1rpm
B-13	Strength when pully fix	KH1	10~100	40			1
B-14	Distance recovered when pully fix	KH2	10~1000	20			1
B-15	Speed reduction rate from stop sign to location detection speed	accelA	2~100	60	40	35	2
B-16	Speed increase rate	accelB	10~100	70	70	25	1
B-17	Speed reduction rate	accelC	10~100	30	40	15	1
B-18	Speed reduction rate from location detection speed to stop	accelD	2~100	6	8	5	1
B-19	Sewing machine inertia value	Inertia	0~255	0			Inertia tuning
B-20	Not used	SPMUPPER	-	-			-
B-21	Highest stop position of UDC	UPPosition	0~8000	440	720	4000	1
B-22	Not used	IND_REFM	-	-			-
B-23	Second P-Gain	KF2A	0-1000	250	400	200	1
B-24	Second D-Gain	KF2C	0~5000	2500	3000	500	1
B-25	SM PULLY SIZE	PULY_SIZEM	0~8000	880	1440	8000	1
B-26	Lowest stop position	CutStartM	0~358	70			1
B-27	Upper stop position	CutEndM	0~358	800	0	0	Fortuna III is a fixed value
B-28	Synchro sensor detection time	SLockTmM	5~1275	40 × 0.1			0.5s
B-29	Overload detection time	OvLoadM	5~1275	30 × 0.1			0.5s
B-30	Motor fixing is possible/impossible, while the machine is not in operation	HOLD_FG	0: impossible 1: possible	0: impossible			1
B-31	Direction of servo motor rotation	DIR_MODE	0: anti-clock 1: clockwise	1: clockwise			1
B-32	Original point sensor detection time	Orgtm	4-1020ms	500ms			4ms

※ Shaded Areas

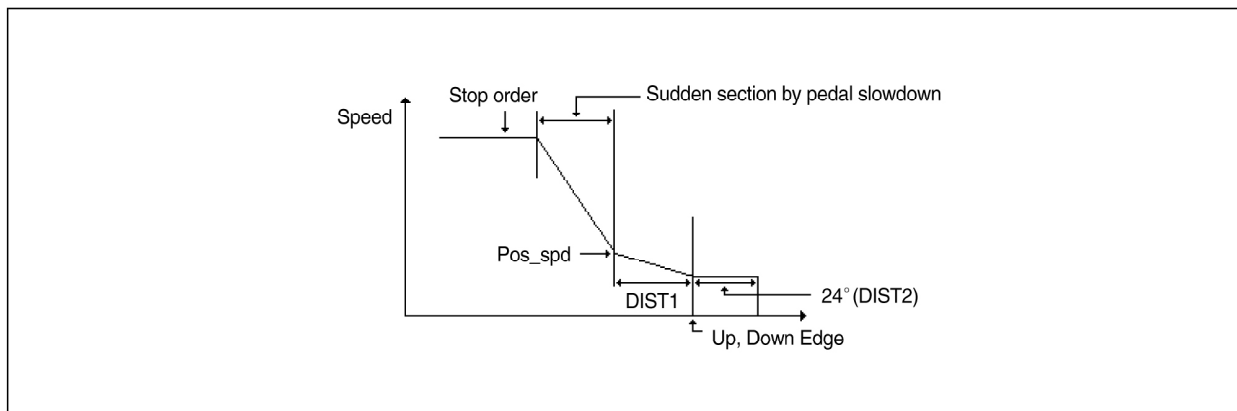

- B-04 (DIST1): A location where sudden speed reduction takes place for stop. The higher this value, the more stable speed reduction, but final stop distance will be longer.
- B-08 (KC2): Can be calculated by inertia tuning. The higher this value, the slower the distance tracking. (FOR PROFESSIONAL ENGINEERS ONLY)
- B-12 (KF2): Can be calculated by inertia tuning. The higher this value, the slower the speed tracking. (FOR PROFESSIONAL ENGINEERS ONLY)
- B-15 (accelA): Can be calculated by inertia tuning. This represents speed reduction from after pedal stop signal input to sudden stop. The higher value means sudden slowdown, but too high value may result in inability to sudden slowdown.
- B-17 (accelB): Represents level of speed acceleration by pedal. The higher this value, the higher acceleration to the target speed, but speed fluctuation may also increase when reaching the target speed.
- B-18 (accelC): Represents level of speed reduction by pedal. The higher this value, the faster reduction of speed to the target speed, but speed fluctuation may also increase when reaching the target speed.

※ Examples of the shaded functions

- ① Unable to come to sudden stop and stops at one more stitch
  - This happens when the machine has been operating at a very high speed or when the workload is large and the machine cannot reduce speed in short time. Increase B-04 and B-15 values to an appropriate level.
- ② Motor is slow to adjust to new speed when machine speed is changed
  - This happens when the speed change level is smaller than the machine workload change. Increase B-17 and B-18 values to an appropriate level.

# 7

## Maintaining/Repairing

### 7-1) Cleaning C/B



**Caution**

Turn off the power before cleaning the machine to prevent accidents associated with mistaken machine operation.



[Inside C/B]



[C/B Rack Structure]

Clean the cooling fan and the inside of the control box on a weekly basis.

No.	Board type
1	Power board
2	Digital board
3	Step board
4	Main shaft board

### 7-2) Replacing Fuse



**Caution**

- To prevent electric shock, wait 5 minutes after power off to open the cover.
- Make sure to turn the power off when opening the control box. Change to a fuse of a designated capacity.

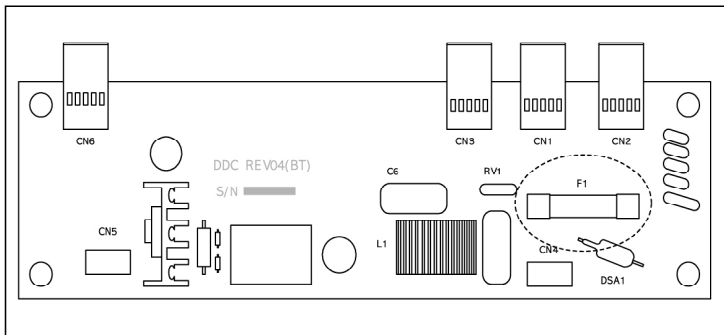

7 fuses are required.

No.	Capacity	Use
F1	15A	Main power protection

### 7-3) Testing the Machine

Test each part of the machine. If malfunction is found, address the relevant electrical errors.

- ※ To use the machine test function after running the machine test, press **[SELECT]** and then move by using **[+/FORWARD]** and **[-/BACK]**. To completely stop the machine test and then start sewing, turn off the power and turn it back on again.

#### (1) Running Machine Test

1. Turn on the power using **[P1]**, **[P2]**, and **[P3]** simultaneously.
2. TEST sign will briefly appear on the screen and you will then see “t-01”.

#### (2) Testing Step Motor Drive and Original Point Sensor

1. Turn on the Machine Test and press **[READY]**.
2. Press the relevant key and the needle will move.
3. X-axis original sensor signal and Y-axis original sensor signal will appear on X-scale lamp and Y-scale lamp, respectively.
4. You will know it is OK if the above two lamps are on when the needle is on the left upper side of the feed plate.
5. End the test by pressing **[SELECT]**.

#### (3) Solenoid Test

1. Run the Machine TEST and then press **[+/FORWARD]** and **[-/BACK]** to display “t-02”.
2. Press **[READY]**.
3. Press the relevant key to run the solenoid and the relevant lamp will turn on.
4. Press **[SELECT]** to end the test.

- ※ Wiper solenoid is an optional function for pneumatic specification -20
- ※ For 0504 (pattern taker), RESET button will serve as a presser foot solenoid and the key will activates upper feed plate in pneumatic type.

#### (4) Testing Main Shaft Motor

1. Run the Machine 'TEST' and then press **+/FORWARD** and **-/BACK** to display "t-03".
2. Press **READY**.
3. Press **READY** and the motor will rotate. Speed of the main shaft motor will be displayed on the screen. Press **READY** again to stop.
4. Adjust the speed using **+/FORWARD** and **-/BACK** keys.
5. Press **SELECT** to end the test.

#### (5) Testing Encoder

1. Run the Machine TEST and then press **+/FORWARD** and **-/BACK** to display "t-04".
2. Press **READY**.
3. Rotate the pulley clockwise and the screen will display encoder angle. No lamp will turn on.

**◀ CAUTION ▶**  
**No change in value means encoder-related errors including connector.**

4. Press **SELECT** to end the test.

#### (6) Testing Synchronizer

1. Run the Machine TEST and then press **+/FORWARD** and **-/BACK** to display "t-05".
2. Press **READY**.
3. Rotate the pulley manually. The screen will display the rotation number and the No. lamp will display synchro signal.

**◀ CAUTION ▶**  
**No change in value after more than one rotation means synchro-related errors including connector.**

4. Press **SELECT** to end the test.



(7) Testing Pedal Input

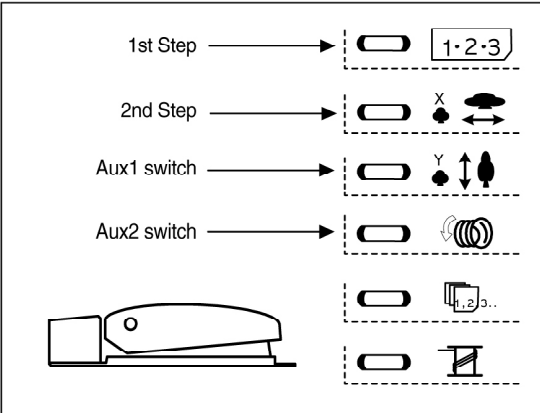

The diagram shows a pedal with four steps: 1st Step, 2nd Step, Aux1 switch, and Aux2 switch. Below the pedal, there are icons for each step: 1-2-3, X, Y, and a speed lamp icon. A legend at the bottom shows icons for 1, 2, 3, and a speed lamp.

1. Run the Machine TEST and then press **+ / FORWARD** and **- / BACK** to display “t-06”.
2. Press **READY**.
3. Press pedal to 1st step and No. lamp will turn on. Press to 2nd step and you will see X-scale lamp be lit. Pressing Aux 1 switch will turn on Y-scale lamp and Aux 2 switch on speed lamp.
4. Press **SELECT** to end the test.

(8) Testing Auxiliary Output

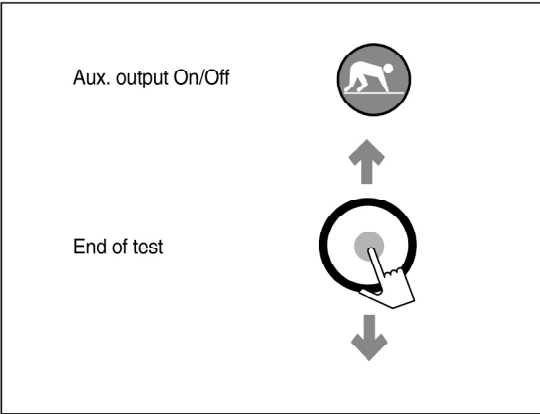

The diagram shows a dog icon and a hand icon. The dog icon is labeled 'Aux. output On/Off' and the hand icon is labeled 'End of test'.

1. Run the Machine TEST and then press **+ / FORWARD** and **- / BACK** to display “t-07”.
2. Press **READY**.
3. Press **READY** to light on all of the 8 auxiliary output (J11 on digital circuit board). Press **READY** again to turn off all of them.
4. Press **SELECT** to end the test.

(9) Testing Auxiliary Input

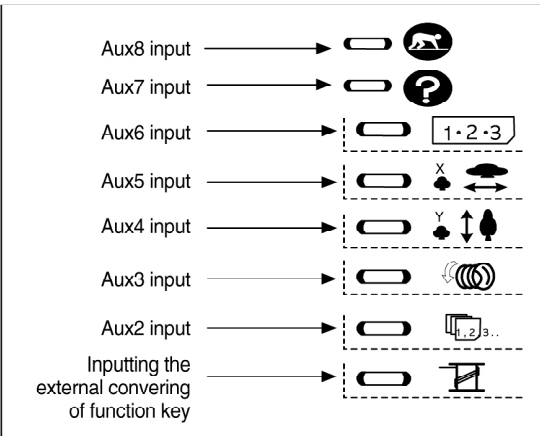

The diagram shows eight auxiliary inputs: Aux8 input, Aux7 input, Aux6 input, Aux5 input, Aux4 input, Aux3 input, Aux2 input, and Inputting the external converging of function key. Each input has a corresponding icon: a dog, a hand, 1-2-3, X, Y, speed lamp, 1, 2, 3, and a speed lamp.

1. Run the Machine TEST and then press **+ / FORWARD** and **- / BACK** to display “t-08.”
2. Press **READY**.
3. Relevant lamps will be turned on according to the 8 auxiliary input signals (J9 on the digital circuit board).
4. Press **SELECT** to end the test.

**◀ CAUTION ▶**  
**Inputting air pressure reduction only applies to pneumatic type.**

## (10) Testing Clamp Solenoid Operation

1. Run the Machine 'TEST' and then press **+/FORWARD** and **-/BACK** to display "t-09".
2. Press **READY**.
3. Press **SELECT** to set the delay times for clamp moving up and down. Use **+/FORWARD** and **-/BACK** keys to change the delay time.
4. Press **RESET** to end the test.

## 7-4) Other Functions

### (1) Initializing Memory Switch

You can initialize the memory switch back to the default condition.

- 1) Turn on the power pressing **+/FORWARD** and **-/BACK** at the same time.
- 2) Memory switch will be initialized with the screen like below.
- 3) You will soon see the initial screen.

**◀ CAUTION ▶**

**Memory switch initialization will remove all of your memory switch set-ups.**

### (2) Inertia Tuning

The controller performs an automatic inertia tuning suitable to the machine load.

Do not perform this function unless tracking of the sewing speed is too slow or the machine stops at one stitch later.

- 1) Press **READY** and **-/BACK** at the same time to turn the power on.
- 2) The following screen appears.
- 3) Press the foot pedal until it moves to Step 2. The inertia tuning is automatically conducted.

**◀ CAUTION ▶**

**After inertia tuning, the needle bar is stopped at a random position. Therefore, place the needle bar at the origin position, and turn off the power. Soon after, turn on the power again.**

### (3) Formatting Scalable Memory

You can turn the memory (where you downloaded patterns) to the default status.

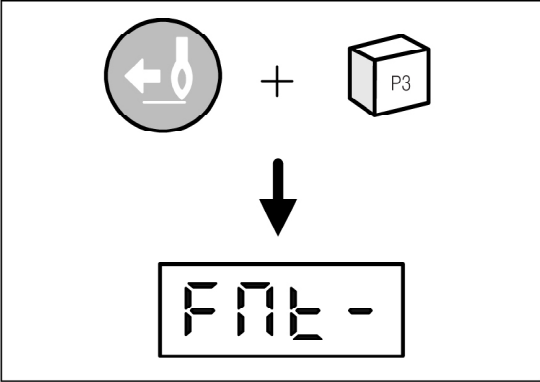

- 1) Turn on the power pressing -/BACK and P3 at the same time.
- 2) Memory will be formatted with the screen like below.

**◀ CAUTION ▶**  
All of your downloaded patterns will be erased.

### (4) Checking Program Version

1) The following screen will appear for around 0.5 seconds after turning on the power. **bH** represents machine model and **16** its version.



Classification	Item	Presser foot error	Pneumatic use	Pneumatic error	Maximum speed	Version display		Upgrade version display	
						Belt	Direct	Belt	Direct
GPS-0402H-20	Pneumatic	×	○	○	2200[spm]	<b>bA16</b>	<b>dA16</b>	<b>9A10</b>	<b>FA10</b>
GPS-0402H-10	Heavy	○	×	×	2700[spm]	<b>bH16</b>	<b>dH16</b>	<b>9H10</b>	<b>FH10</b>
GPS-0402M	Ordinary	○	×	×	2700[spm]	<b>bN16</b>	<b>dN16</b>	<b>9N10</b>	<b>FN10</b>
GPS-0402L	Light	○	×	×	2000[spm]	<b>bL16</b>	<b>dL16</b>	<b>9L10</b>	<b>FL10</b>
GPS-0402K	Knitwear	○	×	×	2000[spm]	<b>bh16</b>	<b>dh16</b>	<b>9h10</b>	<b>Fh10</b>
GPS-0402-BS	Buttoning	○	×	×	2500[spm]	<b>bb16</b>	<b>db16</b>	<b>9b10</b>	<b>Fb10</b>
GPS-0504H-20	Heavy (ordinary) pneumatic	○	○	○	2500[spm]	×	<b>PA04</b>	×	<b>SA10</b>
GPS-0603H-20	Heavy (ordinary) pneumatic	○	○	○	2500[spm]	×	<b>EA02</b>	×	<b>UA10</b>

[Differences in programs and functions by type]

## 7-5) Installing and Replacing ROM

### (1) ROM Types and Classification

① Scalable pattern ROM : This ROM contains sewing patterns made according to user's request and is not installed as a default. It is issued and installed for use at every request from the user.

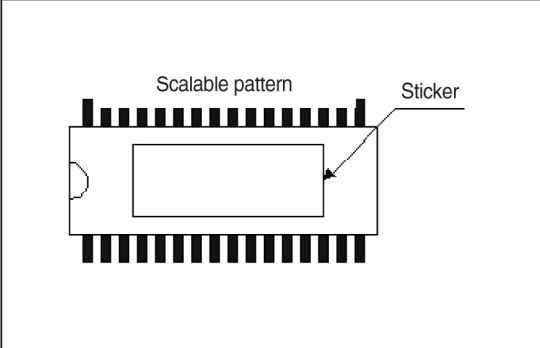

- Sticker : Usually 8 digits, but may be different according to design.  
Ex) bc000928, bj000930 ...

- ② Program ROM : This ROM contains essential programs for operating the sewing machine and is installed as a default. But it should be replaced or updated for adding or changing functions.

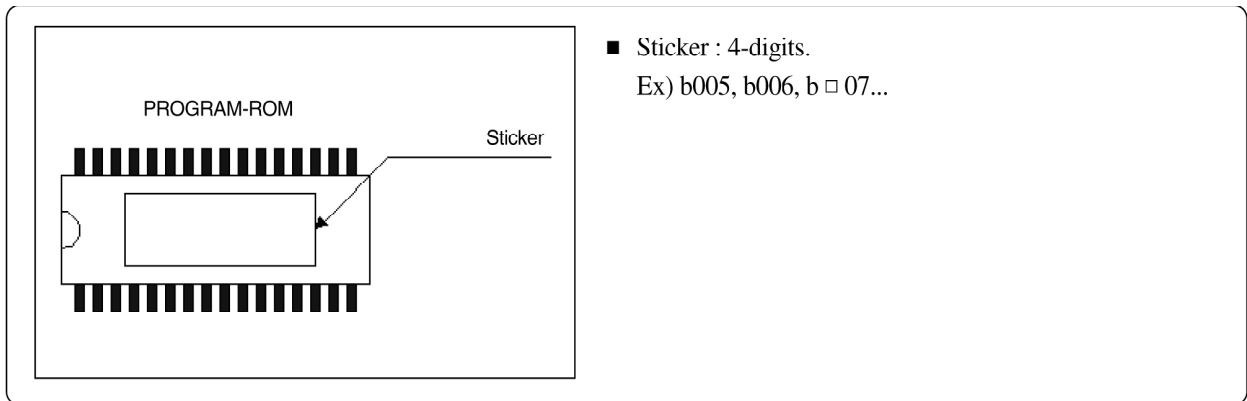

Name	Type	Display on digital board		ROM type		No. of pins	
		Belt	Direct	General	PDA	General	PDA
Scalable pattern ROM	A/B	U9	U18	27C256	AT28C010	28	32
	C/D	U8		×		×	
Program ROM	A/B	U8	U20	27C512	27C512	28	28
	C/D	U7		×		×	

(2) Location of ROM Installation and Precautions



**Caution**

**1) Make sure the power is OFF and the screen is blank before installing/replacing ROM.**

**2) Wrong mark of direction may damage ROM.**

**3) Make sure the pin is installed accurately on the socket.**

**4) When removing the existing ROM, be careful not to damage the board by using IC removing device or small (-) shape screw.**

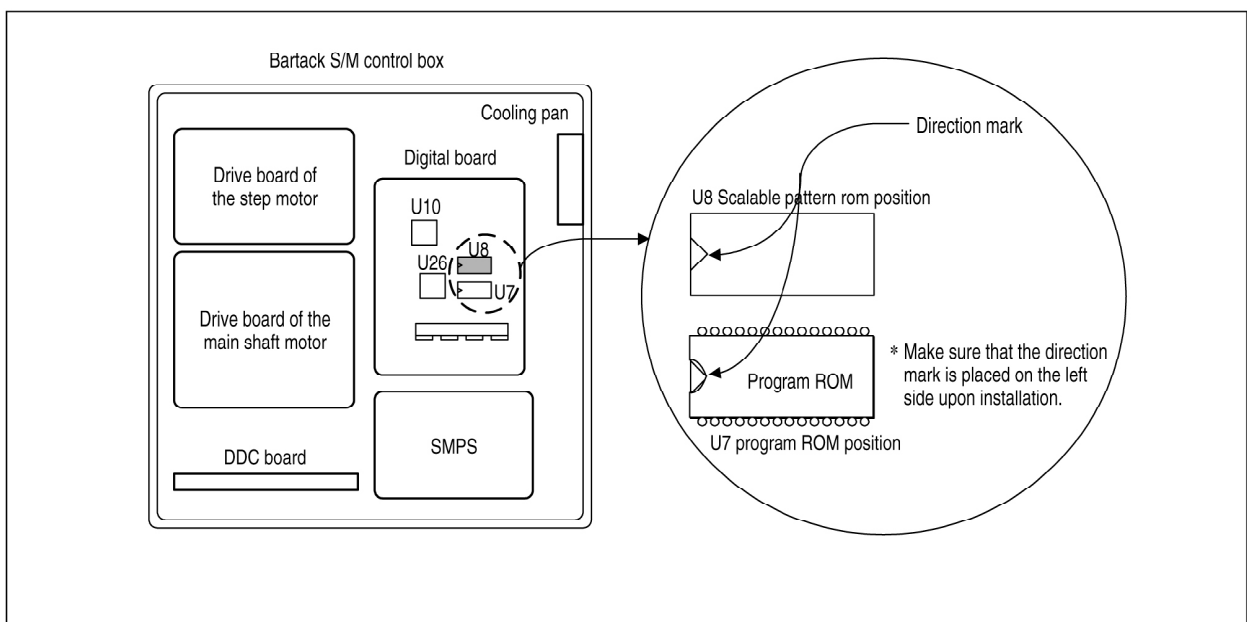

Location of ROM installation

(3) Using Scalable Pattern ROM

① Installing Scalable Pattern ROM

- 1) Take the cover off the Bartack control box.
- 2) As shown in the previous page, install the scalable design ROM onto the “U9” location on the digital board. Make sure to align the direction with the indication on the board (so the direction mark is on the left). Pin should go into the socket accurately.

② Using Scalable Pattern

 <b>Caution</b>	<p>1) If the pattern number is set up by default as call impossible, change the set-up of the pattern to call possible.</p> <p>2) Check the pattern shape and confirm that the needle and the presser plate do not conflict.</p>
---	--

for GARUDAN GPS-0402 series

Ex) Changing the scalable pattern No.33 and No.34 to call possible			
A. Turn on the power, pressing <b>READY</b> and <b>RESET</b> at the same time. Press <b>A</b> and then <b>+FORWARD</b> to display “A-03” on the screen.	➔ <table border="1"><tr><td style="text-align: center;">A - 03</td></tr></table>	A - 03	
A - 03			
B. Press <b>READY</b> to display the present set-up value. ① part : pattern number, ② part : 0 : call impossible, 1 : call possible	➔ <table border="1"><tr><td style="text-align: center;">01 - 1</td></tr><tr><td style="text-align: center;">①      ②</td></tr></table>	01 - 1	①      ②
01 - 1			
①      ②			
C. Press <b>SELECT</b> to change ① “1” to “33”.	➔ <table border="1"><tr><td style="text-align: center;">33 - 0</td></tr></table>	33 - 0	
33 - 0			
D. Press <b>+FORWARD</b> to change ② “0” to “1”.	➔ <table border="1"><tr><td style="text-align: center;">33 - 1</td></tr></table>	33 - 1	
33 - 1			
E. Press <b>SELECT</b> to change ① “33” to “34”.	➔ <table border="1"><tr><td style="text-align: center;">34 - 0</td></tr></table>	34 - 0	
34 - 0			
F. Press <b>+FORWARD</b> to change ② “0” to “1”.	➔ <table border="1"><tr><td style="text-align: center;">34 - 1</td></tr></table>	34 - 1	
34 - 1			
G. Press <b>READY</b> to register.	➔ <table border="1"><tr><td style="text-align: center;">A - 03</td></tr></table>	A - 03	
A - 03			
H. Turn off the power and back on again. Select your desired number.			

## for GARUDAN GPS-0402 BS

Ex) Changing scalable pattern No.34 and No.35 to call possible.

A. Turn on the power, pressing **READY** and **RESET** at the same time. Press **A** and then **+FORWARD** to display "A-03" on the screen.

➔ **A - 03**

B. Press **READY** to display the present set-up value.

Ⓐ part : pattern number, Ⓑ part : 0 : call impossible, 1 : call possible

➔ **01 - 1**  
Ⓐ Ⓑ

C. Press **SELECT** to change Ⓐ "1" to "34".

➔ **34 - 0**

D. Press **+FORWARD** to change Ⓑ "0" to "1".

➔ **34 - 1**

E. Press **SELECT** to change Ⓐ "34" to "35".

➔ **35 - 0**

F. Press **+FORWARD** to change Ⓑ "0" to "1".

➔ **35 - 1**

G. Press **READY** to register.

➔ **A - 03**

H. Turn off the power and back on again. Select your desired number.

## for GARUDAN GPS-0504 series

Ex) Changing scalable pattern No.57 and No.58 to call possible

A. Turn on the power, pressing **READY** and **RESET** at the same time. Press **A** and then **+FORWARD** to display "A-03" on the screen.

➔ **A - 03**

B. Press **READY** to display the present set-up value.

Ⓐ part : pattern number, Ⓑ part : 0 : call impossible, 1 : call possible

➔ **01 - 1**  
Ⓐ Ⓑ

C. Press **SELECT** to change Ⓐ "1" to "57".

➔ **57 - 0**

D. Press **+FORWARD** to change Ⓑ "0" to "1".

➔ **57 - 1**

E. Press **SELECT** to change Ⓐ "57" to "58".

➔ **58 - 0**

F. Press **+FORWARD** to change Ⓑ "0" to "1".

➔ **58 - 1**

G. Press **READY** to register.

➔ **A - 03**

H. Turn off the power and back on again. Select your desired number

## 7-6) Pattern download from PDA (or PC)

### ■ How to download patterns

A. Turn on the power, while press <b>READY</b> and <b>Serial Download</b> at the same time. The screen displays “Prog”.	➔	<b>Prog</b>
B. Press <b>READY</b> and the screen displays “r-33”.	➔	<b>r - 33</b>
C. Use <b>+ / FORWARD</b> to change “r-33” to “r-40”.		
D. Press <b>READY</b> . The screen displays “doUn” and then the download standby mode.	➔	<b>r - 40</b>
※ Pattern transfer from PDA (or PC)	➔	<b>doUn</b>
E. When pattern transfer is completed, the screen displays “End”.		
◀ <b>CAUTION</b> ▶ Whenever one package transfer is completed, a beep sound is issued.	➔	<b>End</b>
F. Press <b>RESET</b> , and the screen displays “r-40”.		
◀ <b>CAUTION</b> ▶ In order to continue to download other patterns, repeat the procedures above from B to E.	➔	<b>r - 40</b>
G. Press <b>SELECT</b> , and the screen displays the sewing mode.		
◀ <b>CAUTION</b> ▶ The screen displays the pattern numbers stored in the memory.	➔	<b>X X</b>
H. Use <b>- / BACK</b> or <b>+ / FORWARD</b> to select downloaded pattern numbers.		
	➔	<b>40</b>
I. Press <b>READY</b> and conduct sewing by stepping on the pedal.		

### ■ The total number of stitches and beep sounds, when patterns are downloaded from PDA(or PC) to the machine

Type	Total No. of Stitches Downloaded (Number of packages)	Number of beep sounds
<b>GPS/C-0402 Series</b> <b>GPS/D-0402 Series</b>	500 stitches (4 packages)	4
<b>GPS/D-0504 Series</b>	1000 stitches (8 packages)	8

※ 1 package = 125 stitches

## 7-7) Pattern download from CF card

### ■ How to download patterns

A. Turn on the power, while pressing **READY** and **CF Card Download** at the same time. The screen displays “CF--”.



CF --

B. Select the mode conversion key.

Mode Key	Description	Screen display	
		Normal status	Error status
P1	Check whether there is a CF card	CF. OK	CF. Er
P2	Check the machine type	MC. bt	MC. Er
P3	Check the directory where patterns are stored	BL05	BL. Er
P4	Check patterns in the chosen directory	05.10	05. Er
P6	Execute downloading	doUn	-

C. Use “P1” to check whether CF is properly operating.

- If there is no error, the screen displays “CF.OK” and then “Mode”.
- If there is an error, the screen displays “CF.Er”. Check CF and then press “P1” again to find out whether it is properly operating.



CF. OK



ModE

D. If CF is properly operating, press “P3” and examine the folder where patterns are stored.

- Press “P3” once, and the screen automatically displays the initial position where the folder exists.
- Press “P3” again, and the screen displays the next folder.
- Choose the desired folder and press **READY** to store the folder location. Then the screen displays “Modc”.



BLO5



Caution

#### How to create a folder (directory) in the CF (CF reader is needed)

- 1) Create a folder named “Bbtk” for bartack-type machine in the CF card.
- 2) Create the pattern block folders (up to 96 folders can be created).
- 3) Create a folder name by entering Blk first, followed by a two-digit number, such as Blk00, Blk01, Blk02, ..., Blk95.  
If the naming rule is not followed, the folder name cannot be displayed on the screen.
- 4) If there are no patterns within a folder, “BL.Er” is displayed on the screen.
- 5) A CF reader shall be additionally purchased by a user.



E. Press “P4” and the chosen folder is examined for pattern files.

- Press “P4” once, and the initial position of the pattern file within the chosen folder is displayed.

Ⓐ Folder name      Ⓑ Pattern file name

- Press “P4” again, and the next pattern file position is displayed.
- Choose the desired pattern file and then press **READY** to store the location of the pattern file. The screen displays “Mode”.



05. 10  
Ⓐ      Ⓑ



Caution

**How to create pattern files (in case of SSP-WE/2.0)**

1) Up to 96 pattern files can be stored within a folder.

2) Create a folder name by entering a two-digit number followed by extension “.btk” such as 00.btk, 01.btk, 02.btk, ..., 95.btk .

If the naming rule is not followed, the folder name cannot be displayed on the screen.

3) If there are no patterns within a folder, “FL.Er” is displayed on the screen.

F. Press “P6”, and the screen displays “r-33”.



r - 33

G. Use **+ /FORWARD** and change “r-33” to “r-40”.



r - 40

H. If **READY** is pressed, the screen displays “doUn”, and then the standby mode.



doUn

I. When **CF Card Download** is pressed, it is checked whether CF is existing. If no error is found, pattern data are transferred. When the transfer is completed, the screen displays “End”.



CF.OK

- When an error occurs displaying “CF.Er” on screen, examine the CF card and press “P1”. The screen displays “doUn”, and the patterns are automatically transferred.



End

◀ CAUTION ▶

Whenever one package transfer is completed, a beep sound is issued.

J. Press **RESET**, and the screen displays “CF--”.



CF --

- In order to continue to download other patterns, repeat the procedures above from E to I.
- If the pattern download is desired from other folder, repeat the procedures above from E to I.

K. Press **SELECT**, and the screen displays the sewing mode.

◀ CAUTION ▶

The screen displays the pattern number stored in the memory.



40

L. Use **- /BACK** or **+ /FORWARD** to select the downloaded pattern number.

M. Press **READY**, and conduct sewing by stepping on the pedal.

# 8

## Error List

No.	Display	Description	Error tone
1	Er01	Pattern call is set "impossible"	×
2	Er02	Error in scale function	×
3	Er03	Error in needle bar position	×
4	Er04	Error in drive limit	×
5	Er05/Err55	Error in clamp position	×
6	Er06	Unable to move to X original point in given time	×
7	Er16	Unable to move to Y original point in give time	×
8	Er36	Original point cable is missing /XY original point sensor failure	×
9	Er07	For pneumatic type (HA), if pneumatic is below standard	×
10	Er08	Error in ROM version against new digital board	×
11	Er10	Alarm that counter is "0"	×
12	Er11	Pin hole cannot go down or move up	×
13	Er12	No or bad scalable ROM	×
14	Er13	Formatting incomplete	×
15	Er14	SPMS fan failure	○
16	Er15	Error in recognizing main motor type	×
17	60, 61	Synchronizer contact error	○
18	126	Error in operating sequence of the main shaft motor	○
19	127	Encoder AB error	○
20	128	Encoder RST error	○
21	129	Main shaft motor overload	○
22	130	Error in synchronizer signal	○
23	9999	Main shaft type error	○
24	EEPr	EEPROM error	○
25	CE17, LC18 BC20, AC19	Communication failure in internal circuit of CPU board	○
26	oPEN	Laying the head on the side for direct-connection type	○
27	orLd	Overvoltage	○

※ Error alarm ○ : Buzzer sound, × : No buzzer sound

※ Connecting Connector to Control Box (direct connection)

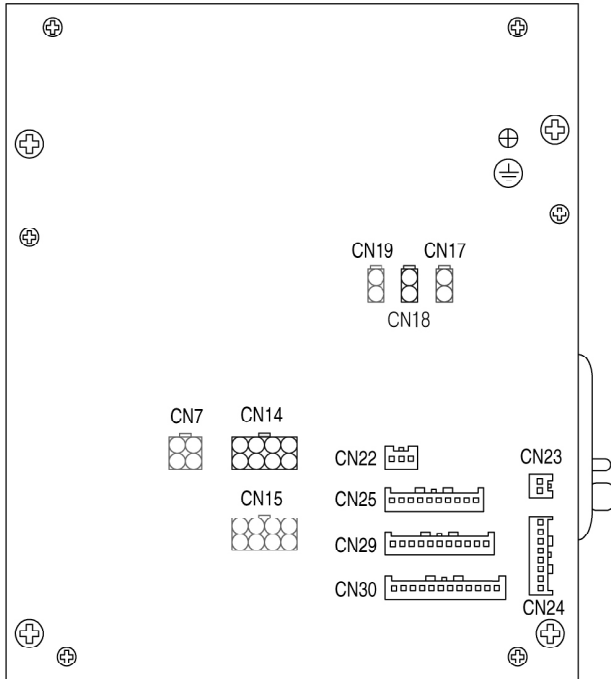

[ Rear Cover of Control Box ]

Cable	Machine	Control box
Presser bar solenoid cable	⑱	CN17
Thread trimming solenoid cable	⑰	CN18
Wiper solenoid cable	⑳	CN19
Main shaft motor (Sanyo) connection cable	⑯	CN7
X-shaft step motor connection cable	⑧	CN14
Y-shaft step motor connection cable	⑨	CN15
Laser pointer (if necessary)	-	CN22
Foot step jumper cable	⑭	CN23
Foot step switch input cable	⑮	CN24
Head safety switch cable	㉒	CN25
Pneumatic output and auxiliary input cable	㉑	CN29
XY origin sensor cable	⑪	CN30

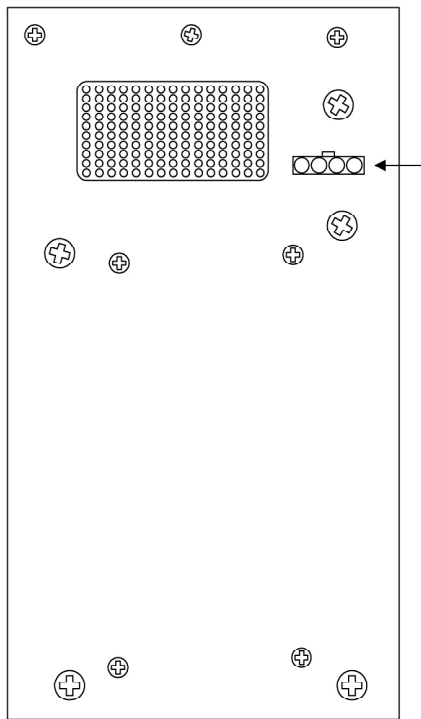

[ Left Side Cover of Control Box ]

Cable	Machine	Control box
External power input cable	②	-

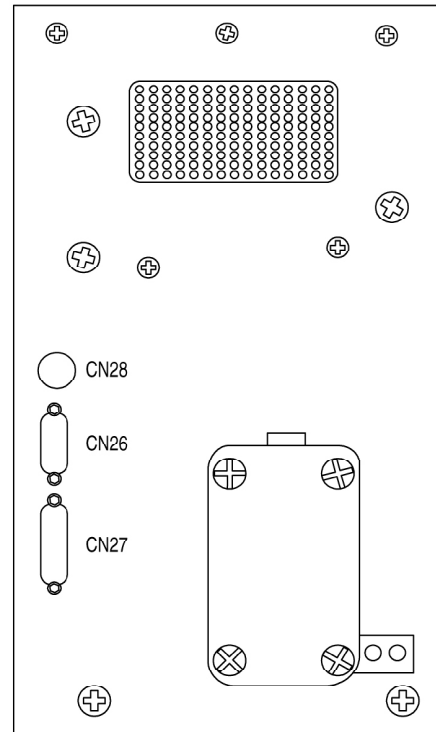

[ Right Side Cover of Control Box ]

Cable	Machine	Control box
Main shaft encoder (Sanyo) input cable	⑮	CN26
OP box connection cable	⑦	CN27
Synch input cable (only for Belt-type)	-	CN28

▶ GPS/C,D-0402 (0504) series Block Diagram

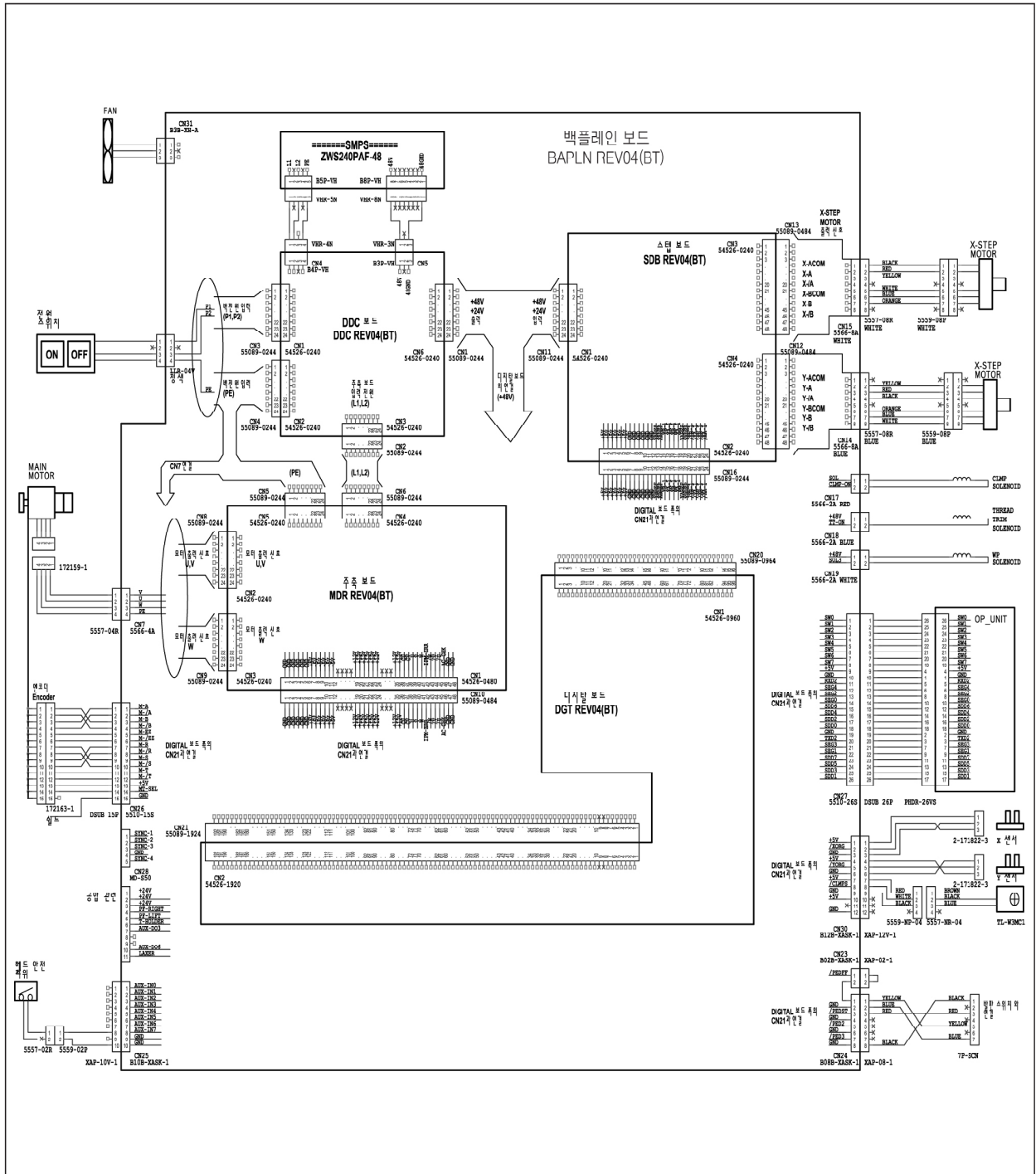

# 9

## How Select the Sewing Pattern List and the Sewing Lange

### 9-1) GPS-0402 series

Application	No.	Pattern	Stitch Number	Range of Sewing	
				X (mm)	Y (mm)
For Heavy and General Materials	1		28	10	2
	2			16	2.5
	3		36	10	2
	4			16	2.5
	5		42	10	2
	6			16	2
	7			16	2.5
	8			24	3
	9		56	24	3
	10		64	24	3
For Thin Materials	11		21	6	2.5
	12		28	6	2.5
	13		36	6	2.5
For Knit	14		14	8	2
	15		21	8	2
	16		28	8	2
Straight Line	17		21	10	0

Application	No.	Pattern	Stitch Number	Range of Sewing	
				X (mm)	Y (mm)
Straight Line	18		28	10	0
	19			25	0
	20		36	25	0
	21		41	25	0
	22		44	35	0
Semi Circle	31		42	11	7
	32		42	11	7

Vertical				
No.	23	24	25	26
Pattern				
Stitch Number	28	36	42	56
Range of Sewing	X (mm)	4	4	4
	Y (mm)	20	20	20

Linear Vertical				
No.	27	28	29	30
Pattern				
Stitch Number	18	21		28
Range of Sewing	X (mm)	0	0	0
	Y (mm)	20	10	20

9-2) GPS-0402-BS series

Pattern No.	Pattern	No. of Threads	Range of Sewing	
			X (mm)	Y (mm)
1		6-6	3.4	3.4
2		8-8	3.4	3.4
3		10-10	3.4	3.4
4		12-12	3.4	3.4
5*		6-6	3.4	3.4
6*		8-8	3.4	3.4
7*		10-10	3.4	3.4
8*		12-12	3.4	3.4
9		6-6	3.4	3.4
10		8-8	3.4	3.4
11		10-10	3.4	3.4
12		6-6	3.4	3.4
13		8-8	3.4	3.4
14		10-10	3.4	3.4
15*		6-6	3.4	3.4
16*		8-8	3.4	3.4
17*		10-10	3.4	3.4











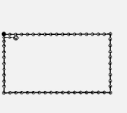

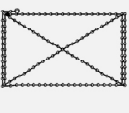
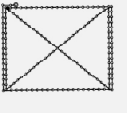
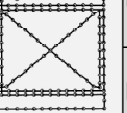
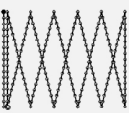
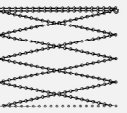
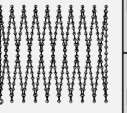

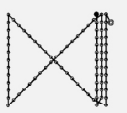



Pattern No.	Pattern	No. of Threads	Range of Sewing	
			X (mm)	Y (mm)
18		6	3.4	0
19		8	3.4	0
20		10	3.4	0
21		12	3.4	0
22		16	3.4	0
23		6	0	3.4
24		10	0	3.4
25		12	0	3.4
26		6-6	3.4	3.4
27		10-10	3.4	3.4
28*		6-6	3.4	3.4
29*		10-10	3.4	3.4
30		5-5-5	2.9	2.5
31		8-8-8	2.9	2.5
32		5-5-5	2.9	2.5
33		8-8-8	2.9	2.5

※ The magnifying and reduction range (X and Y) of standard sewing shown above is 100%. 66 patterns including 33 patterns can be additionally provided.

- A. If the central distance between use buttonholes does not conform for the standard sewing range of Sewing Pattern No., magnify or reduce the sewing range to adjust it.
- B. After the Sewing Pattern Number and the sewing range (X, Y) are changed, don't forget to check if the needle-point conforms to the buttonhole with regard to [Checking Pattern Shape].
- C. Rate of magnifying and reduction according to the sewing range.

Sewing Area X,Y(mm)	2.4	2.6	2.8	3.0	3.2	3.4	3.6	4.0	4.3	4.5	4.7	5.2	5.6	6.0	6.2	6.4
Expansion & Reduction (%)	71	76	82	88	94	100	106	118	126	132	138	153	165	176	182	188

9-3) GPS-0504 series

No.	Pattern	model	Stitch Number	Range of Sewing		No.	Pattern	model	Stitch Number	Range of Sewing		No.	Pattern	model	Stitch Number	Range of Sewing	
				X (mm)	Y (mm)					X (mm)	Y (mm)					X (mm)	Y (mm)
33		B1254	75	50	40	34		B1254	59	45	29	35		B1254	59	30	40
		B1263	75	50	40			B1263	59	45	29			B1263	59	30	40
36		B1254	139	50	30	37		B1254	159	50	40	38		B1254	155	30	35
		B1263	139	50	30			B1263	159	50	40			B1263	155	30	35
39		B1254	219	50	40	40		B1254	229	50	40	41		B1254	335	45	40
		B1263	219	50	40			B1263	229	50	40			B1263	335	45	40
42		B1254	397	50	40	43		B1254	84	30	30	44		B1254	147	35	40
		B1263	397	50	40			B1263	84	30	30			B1263	147	35	40
45		B1254	56	33	30	46		B1254	56	35	35	47		B1254	74	36	36
		B1263	56	33	30			B1263	56	35	35			B1263	74	36	36
48		B1254	78	8	35	49		B1254	116	31	31	50		B1254	109	28	28
		B1263	78	8	35			B1263	116	31	31			B1263	109	28	28
51		B1254	136	28	28	52		B1254	122	40	28	53		B1254	152	34	31
		B1263	136	28	28			B1263	122	40	28			B1263	152	34	31
54		B1254	142	40	24	55		B1254	65	30	8	56		B1254	65	8	30
		B1263	142	40	24			B1263	65	30	8			B1263	65	8	30

Application	No.	Pattern	Stitch Number	Range of Sewing		
				X (mm)	Y (mm)	
For Heavy and General Materials	1		28	10	2	
	2			16	2.5	
	3		36	10	2	
	4			16	2.5	
	5		42	10	2	
	6			16	2	
	7			16	2.5	
	8			24	3	
		9		56	24	3
		10		64	24	3
For Thin Materials	11		21	6	2.5	
	12		28	6	2.5	
	13		36	6	2.5	
For Knit	14		14	8	2	
	15		21	8	2	
	16		28	8	2	
Straight Line	17		21	10	0	

Application	No.	Pattern	Stitch Number	Range of Sewing	
				X (mm)	Y (mm)
Straight Line	18		28	10	0
	19			25	0
	20		36	25	0
	21		41	25	0
	22		44	35	0
Semi Circle	31		42	11	7
	32		42	11	7

Vertical				
No.	23	24	25	26
Pattern				
Stitch Number	28	36	42	56
Range of X (mm)	4	4	4	4
Sewing Y (mm)	20	20	20	20

Linear Vertical				
No.	27	28	29	30
Pattern				
Stitch Number	18	21		28
Range of X (mm)	0	0	0	0
Sewing Y (mm)	20	10	20	20

- Note) 1. Pattern No. 33 to No. 56 are for label, waving, etc, works.  
2. Pattern No. 1 to No. 32 are for Bartack works. Please work after the option gauge has been mounted.  
(When operating Bartack works, be sure to use the standard shuttle hook or the standard bobbin case)  
(In case of Pattern No. 1 to No. 3 and No. 47 to No. 56, Please use it by lowering the maximum sewing speed [below 2,200 spm].)  
3. The status of sewing shall be not uniform according to the kind of sewing materials and other conditions in case of patterns fo Bartack works.  
4. Besides the above 56 Patterns, it is available to provided with 43 patterns additionally.  
(Maximum 99 patterns)



# 10. BASIC MANUAL

## GARUDAN GPS/C (GPS/D) series

- 1 **General Sewing** : Sew by setting the sewing pattern, extension and reduction rate and sewing speed.
- 2 **Use of Using Program** : Conveniently call the sewing pattern that you frequent use.
- 3 **Use of combined function** : Sew by combining the sewing pattern in the order that you want.
- 4 **Sewing Pattern Confirming** : Confirm whether the sewing pattern and presser plate are interfered.

